

358

Thick Shake Freezer



Features

Serve a wide variety of frozen desserts, like thick shakes and smoothies, with the assurance of safe temperatures for dairy products. Direct draw a single flavor, or blend in flavorings for more variety.

Freezing Cylinder

One, 7 quart (6.6 liter).

Refrigerated Mix Hopper

One, 20 quart (18.9 liter). Refrigerated to maintain mix temperature below 41°F (5°C).

Indicator Lights

If the freezer is out of mix, the Mix Out light will come on, and the freezer shuts down automatically to prevent damage. Less than one pint (.5 liter) is left in the hopper when the mix out system is activated.

Solid State Controls

Thermistor control precisely monitors temperature and maintains consistent quality in product texture through solid state technology.

Thumb Grip Draw Handle

Draw handle makes dispensing of product easy by squeezing two levers together.

Fast Ejection

Beater design ejects product quickly to serve customers faster. Dispense a 16 fl. oz. (473 ml) serving in approximately 3 seconds.

Plastic Hopper Cover

Durable, plastic hopper cover maintains its shape through years of use.



Standard 6



LISTED
SA2650



Selected 50
Hz. Models

358 Thick Shake Freezer

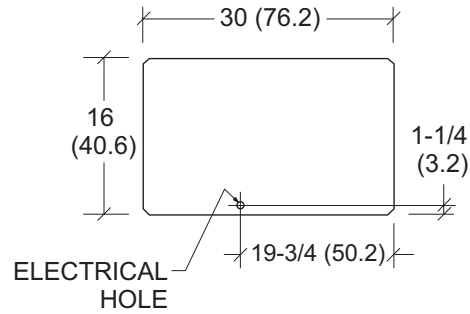
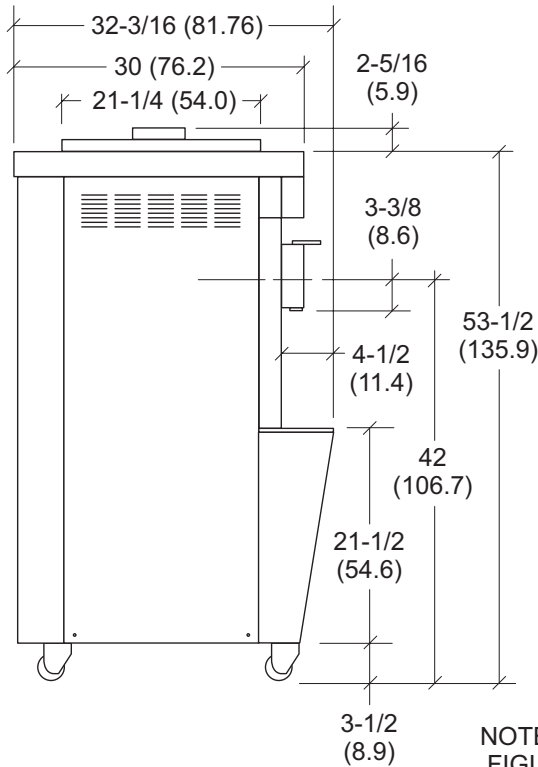

TOP VIEW - OPERATOR END
ALL CONNECTIONS LOCATED UNDERSIDE OF BASE

NOTE:
FIGURES IN PARENTHESES INDICATE MILLIMETERS.

Weights	lbs.	kgs.
Net	356	161.5
Crated	400	181.4
	cu. ft.	cu. m.
Volume	22.3	0.63

Dimensions	in.	mm.
Width	16	406
Depth	32-3/16	818
Height	55-7/8	1418
Counter Clearance	3-1/2	89

*Mounted on standard casters

Electrical	Maximum Fuse Size	Minimum Circuit Ampacity	Poles (P) Wires (W)
208-230/60/3 Air	20	16	3P 4W
380-415/50/3N~ Air	9	7	4P 5W

This unit may be manufactured in other electrical characteristics. Refer to the local Taylor Distributor for availability.
(For exact electrical information, always refer to the data label of the unit.)

Bidding Specs

Electrical: Volt _____ Hz _____ ph _____
Neutral: Yes No | Cooling: Air Water NA

Options: _____

Specifications

Electrical

One dedicated electrical connection is required. See the Electrical chart for the proper electrical requirements. Manufactured to be permanently connected. Consult your local Taylor distributor for cord & receptacle specifications as local codes allow.

Beater Motor

One, 1.5 HP.

Refrigeration System

One, approximately 9,500 BTU/hr. R404A.
BTUs may vary depending on compressor used.)

Air Cooled

Minimum Clearance: 3" (76 mm) around all sides. Minimum air clearances must be met to assure adequate air flow for optimum performance.

Options

- Bumper Kit

Continuing research results in steady improvements; therefore, these specifications are subject to change without notice.



Taylor Company,
A division of Carrier Commercial Refrigeration, Inc.
Rockton, Illinois 61072
815-624-8333 **800-255-0626** Fax 815-624-8000
www.taylor-company.com

Printed in U.S.A.

56749-ADV 1/08